

## NEMO® Progressing Cavity Pumps

Comprehensive and uncompromised solutions for all industries

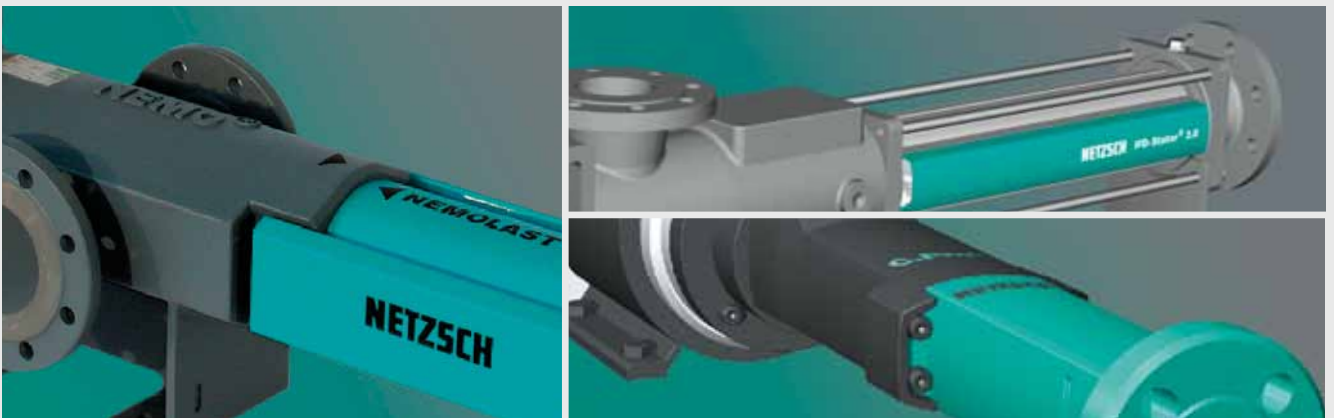

# NEMO® Progressing Cavity Pumps

## Good reasons for choosing NETZSCH technology

**NETZSCH® has been developing and building high-quality and innovative pump systems for six decades at six sites worldwide as exclusive supplier under international patents.**

Always focused on benefit to the customer, the NETZSCH product range covers everything from the smallest dosing pumps conveying a few millilitres to large pumps for up to 1000m<sup>3</sup>/h. NETZSCH also offers grinders and comprehensive accessories. We supply everything in and around the pump to suit your application perfectly, because we understand and know your process.

We guarantee proximity to our customers in 23 branches and more than 130 agencies around the world. Our application-oriented sales structure spanning seven business fields ensures that each of your contacts at NETZSCH has detailed knowledge of applications, that national and international standards are complied with, and that contact routes are short, delivery is fast and on-site service is competent.

The following pages offer you an overview of the entire range of NEMO®

progressing cavity pumps. Each individual design is optimised to suit the specific application requirements, to guarantee best performance, prolonged lifetime and reliability.

The pumps are available with conveying systems in four different rotor/stator geometries, which means the pump can be configured specifically for your application. (pages 14 and 15)

Another benefit from our continued investment in product development is a range of gear joints selected to suit each and every application no matter how demanding. (pages 16 and 17)

And last but not least, we provide accessories and service, as we want you to stay in close contact with NETZSCH even after your pump has been commissioned. (pages 18 and 19)

Please see for yourself and contact us

NETZSCH Pumps & Systems – Solutions you can trust ■

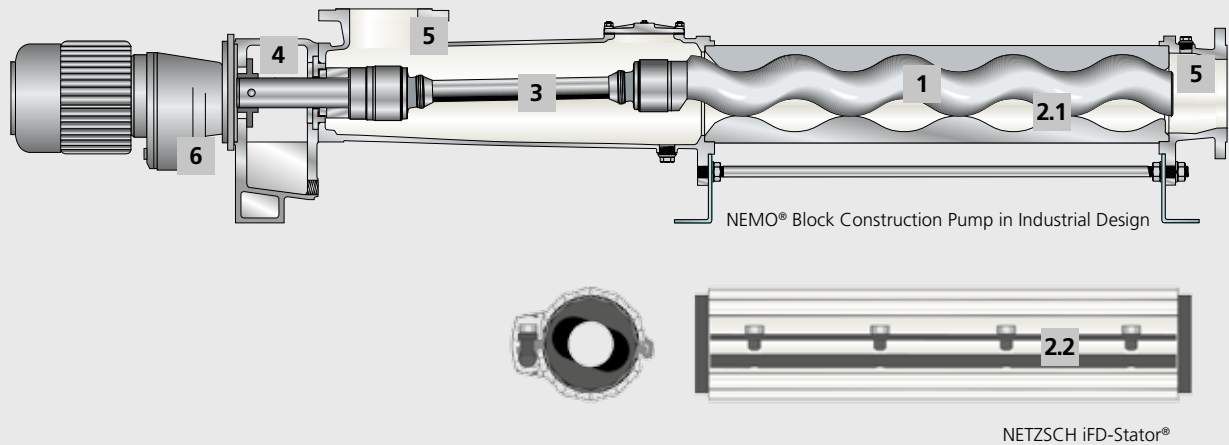

## 1 Rotor

In wear and corrosion resistant design, including the wear-free ceramic rotor, NEMO CERATEC®.

## 2 Stator

We manufacture stators to the latest standards. Stators minimise the tolerance range thereby optimising the performance of the pump. Our unique, fully networked production and process data monitoring system, developed in-house, is backed up by consistent quality testing.

### 2.1 Stator with Conventional Technology

Vulcanised into a tube, with integrated seals on both ends in a variety of NEMOLAST® elastomers, plastics or metals. Stator inlet with chamfer to facilitate the entry of the fluid into the conveying chamber.

### 2.2 Stator with iFD Technology

The stator consists of a disposable elastomer part and an aluminium outer sleeve in which the NEMOLAST® elastomer is housed. The advantages of this new technology are the reduced starting torque, the higher degree of efficiency, longer lifetime, simple and quick change as well as the easy disposal.

For further information of the iFD-Stator® simply order brochure NMP · 344

## 3 Drive Chain

Plug in shaft with coupling rod and two universal joints for power transmission from the drive to the rotor.

## 4 Shaft Seal

Standard design with single-acting, wear resistant, bi-directional mechanical seal; on request different types of single/double-acting mechanical seals

by various manufacturers, cartridge and other special seals as well as gland packing.

## 5 Suction and Pressure Housing

Designed to optimise through flow with flanges or threads according to DIN and other international standards.

Materials in cast iron, chromium nickel molybdenum steel, rubber-coated or Halar® cast iron as well as special materials according to specifications.

Halar® is a registered trademark of Solvay Solexis

## 6 Block Construction Design

A drive flanged directly to the housing reduces length, weight and gives a constant shaft height, independent of construction and size of the drive. It is both maintenance- and service-friendly as well as economical.

# NEMO® Progressing Cavity Pumps

## Characteristics and Typical Components

**NEMO® progressing cavity pumps are utilized in various industries to convey many types of fluids in a continuous, low pulsating manner, while maintaining an accurate flow.**

### Wide Range of Applications

The pumps are specifically designed for products with the following characteristics:

- High solids content (maximum particle size up to 6"/150 mm) and free of solids
- Low to high viscosity (1 mPas – 3 million mPas)
- Thixotropic and dilatant
- Shear-sensitive
- Abrasive
- Lubricating and non-lubricating
- Aggressive (pH 0 – 14)
- Adhesive
- Toxic

### Large Range of Capacities and Pressures

- Capacities from a few millilitres up to 500 m<sup>3</sup>/h (2,200 gpm)
- Number of stages ranging from 1 up to 8 for pressures from 6 (90 psi) up to 48 bar (680 psi) as standard, up to 240 bar (3,400 psi) as high pressure

### Various Conveying Elements

Four different rotor/stator geometries are available allowing optimisation of the pump characteristics for specific applications. For further details see pages 14 and 15.

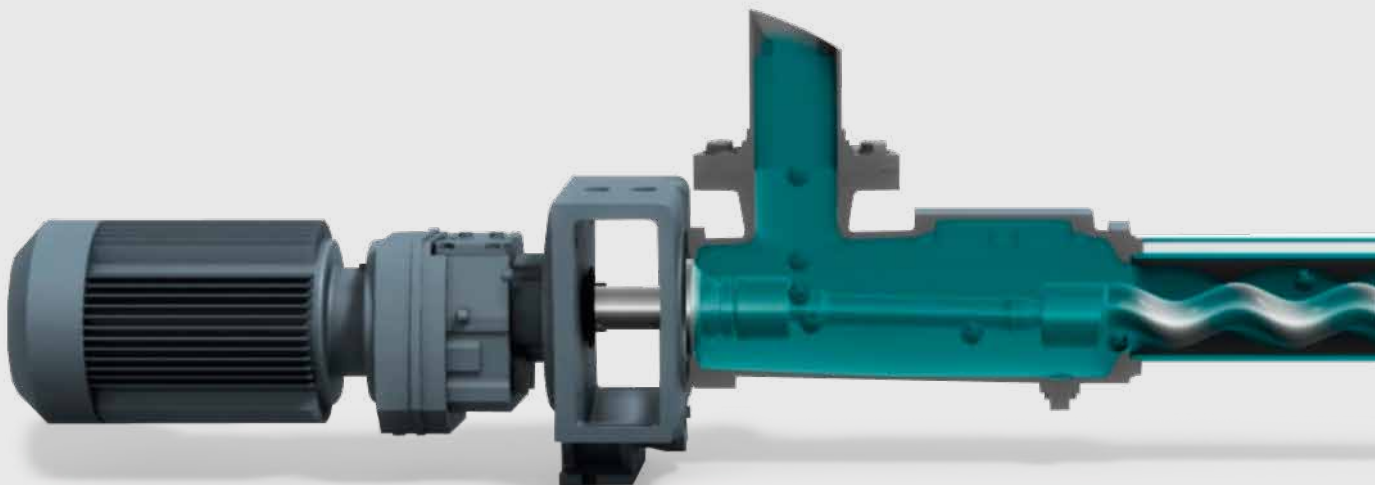

## Extensive Range of Materials of Construction

Wetted parts are available in numerous materials. Standard housings are made of cast iron and stainless steel. Parts are available in mild steel, stainless steel and tool steel. Other materials are available upon request. Elastomers like highly abrasion resistant natural rubber, oil-, acid- and alkali-proof elastomers, Aflas and Viton are available. When elastomers cannot be used due to high temperatures or compatibility reasons, NETZSCH offers a variety of solid materials.

## A Wide Variety of Shaft Sealing Options

Shaft seals range from single-acting mechanical seals, with and without quench, to double-acting mechanical seals in back-to-back or tandem arrangement as well as cartridge seals as per customer specification. For certain applications there are gland packings, lip seals and specially designed seals. In the case of toxic fluids we offer a pump with a magnetic coupling which is 100% leakproof.

## Additional Features

- High suction capability up to 9 mwc (30 ftwc)
- Reversible direction of rotation and thus flow
- Installation in any position
- Smooth and quiet operation
- Temperatures of - 20 up to + 200 °C (- 5 up to + 570 °F)



# NEMO® Progressing Cavity Pumps

## Applications, Performance and Product Range

### NEMO® M.Champ®

in block construction design with maintenance free flexible rod and integrated reserve stator

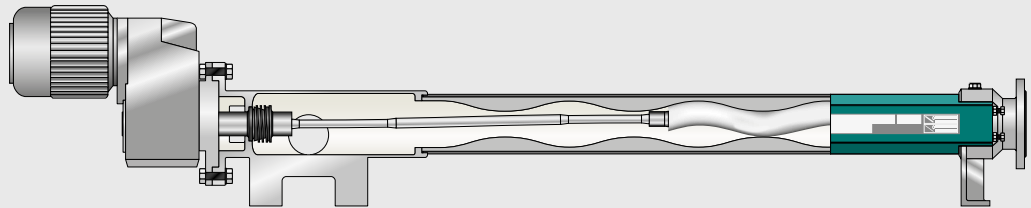

#### Performance

Capacities up to 85 m<sup>3</sup>/h (360 gpm). Pressures up to 6 bar (85 psi).

#### Range of Applications

Industrial applications in environmental industries for low to highly viscous fluids with or without solids.

#### Further information

NEMO® M.Champ®  
Brochure NMP · 311

#### Description

Compact design with flanged robust IEC parallel shaft gear unit. The patented and integrated NEMOLAST® reversible stator and the simple design guarantee a long service life and low life cycle cost. Increased application possibilities with the use of P or L geometries.

### NEMO® BY

in in block construction design

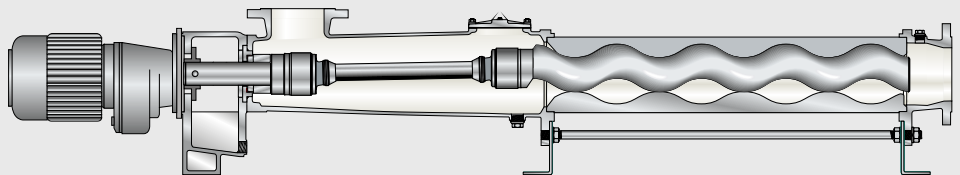

#### Performance

Capacities up to 400 m<sup>3</sup>/h (1,800 gpm). Pressures up to 24 bar (340 psi).

#### Range of Applications

Industrial applications in environmental, food, oil and chemical industries for low and highly viscous fluids with or without solids.

#### Description

Compact design with flanged drive; low investment and operating and maintenance costs. Four rotor/stator geometries for optimised performance.

## NEMO® SY

with bearing housing and drive shaft

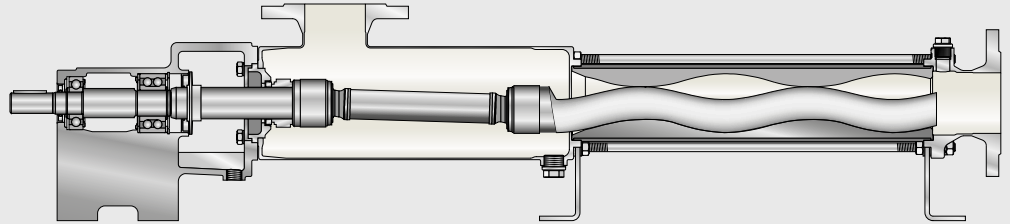

### Performance

Capacities up to 500 m<sup>3</sup>/h (2,200 gpm). Pressures up to 48 bar (680 psi) as standard, up to 240 bar (3,400 psi) as high pressure.

### Range of Applications

Industrial applications in environmental, food, oil and chemical industries for low and highly viscous fluids with or without solids.

### Description

Design with bearing housing and two-piece shaft allows for universal use of all types of drives and easy and quick servicing of the rotating parts. Four rotor/stator geometries for optimised performance.

## NEMO® C.Pro®

plastic dosing pump

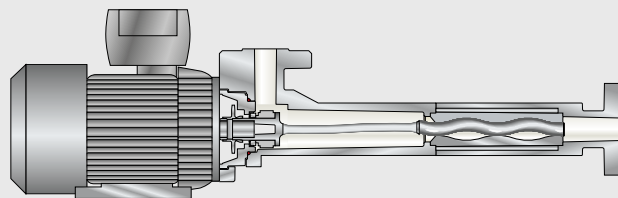

### Performance

Capacities from 0.5 up to 1,000 l/h (0.13 up to 260 gph). Pressures up to 20 bar (280 psi).

### Range of Applications

Industrial applications in environmental and chemical industries for conveying and dosing of fluids of low or medium viscosity with or without solids.

### Description

High dosing accuracy (deviation < 1 %). Compact design with directly flanged drive.

#### Further information

NEMO® C.Pro®  
Brochure NMP · 313

# NEMO® Progressing Cavity Pumps

## Applications, Performance and Product Range

### NEMO® BO/BS

in block construction design with directly flanged drive or as NEMO® SO/SS with bearing housing and drive shaft (no fig.)

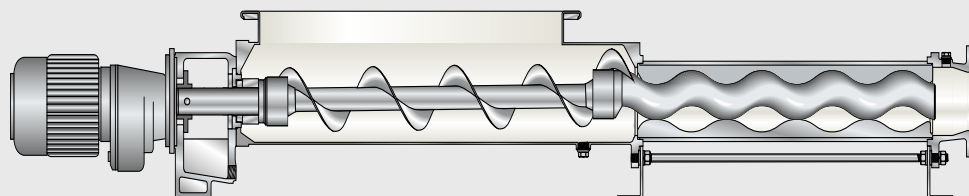

#### Performance

Capacities up to 200 m<sup>3</sup>/h (880 gpm). Pressures up to 24 bar (340 psi).

#### Range of Applications

Industrial applications in environmental, food and chemical industries for highly viscous and non free-flowing fluids with or without solids.

#### Description

Housing with removable rectangular/square hopper and coupling rod with feeding screw with or without force feed chamber for easier entry of the fluid into the rotor and stator.

### NEMO® BF optional with aBP-Module®

in block construction design with directly flanged drive or as NEMO® SF optional with aBP-Module® with bearing housing and drive shaft (no fig.)

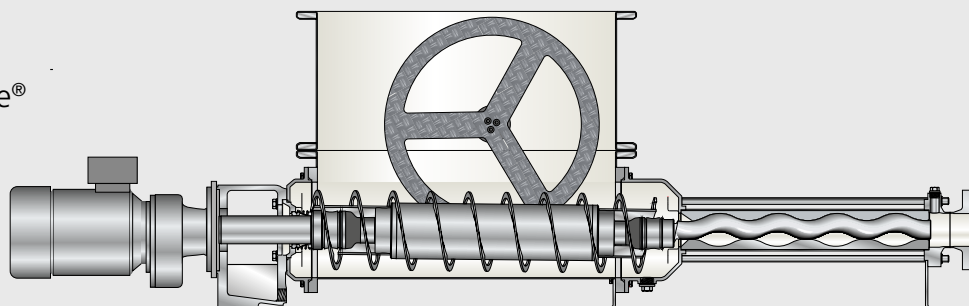

#### Performance

Capacities up to 200 m<sup>3</sup>/h (880 gpm). Pressures up to 48 bar (680 psi).  
NEMO® BF/SF with aBP-Module® available from size NM045 up to NM090.

#### Range of Applications

Industrial applications in environmental and chemical industries for highly viscous, compact and crumbly media that does not have a tendency to bridge. For media which tend to build bridges the pump is available with aBP-Module®.

#### Further information

aBP-Module®  
Brochure NMP · 070

#### Description

Housing with removable, enlarged rectangular hopper and tapered force feed chamber as well as coupling rod with patented, positioned feeding screw for optimal transfer of the medium to the rotor and stator.



## NEMO® BP

in block construction design with directly flanged drive or as NEMO® SP with bearing housing and drive shaft (no fig.)

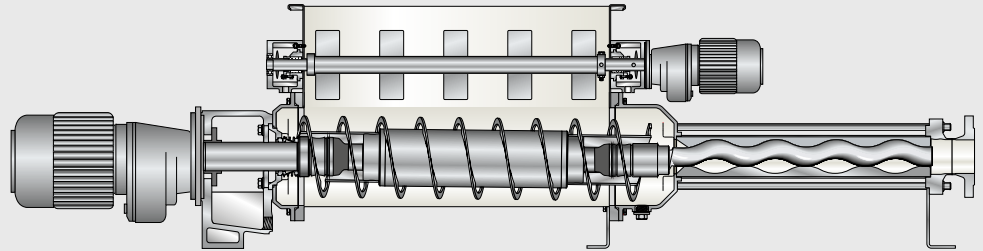

### Performance

Capacities up to 200 m<sup>3</sup>/h (880 gpm). Pressures up to 48 bar (680 psi). NEMO® BP/SP available from size NM090.

### Range of Applications

Industrial applications in environmental and chemical industries for compact and crumbly media that may have a tendency to bridge.

### Description

Housing with integrated bridge breaker, mixing additions, enlarged rectangular hopper and tapered force feed chamber as well as coupling rod with patented, positioned feeding screw for optimal transfer of the medium to the rotor and stator.

## NEMO® B.Max®

in block construction design with directly flanged drive or with bearing housing and drive shaft (no fig.)

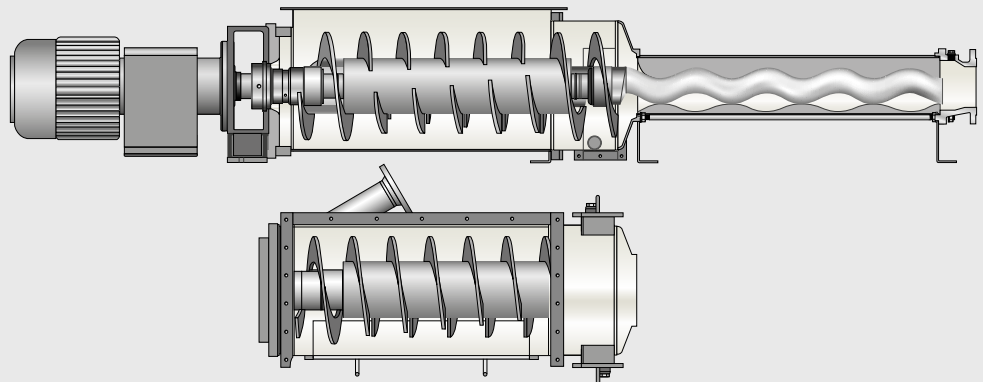

### Performance

Capacities up to 70 m<sup>3</sup>/h (308 gpm). Pressures up to 48 bar (680 psi).

### Range of Applications

Industrial applications in the biogas technology in environmental industries for highly viscous and non free-flowing fluids with or without solids.

### Description

Housing with large, rectangular/square hopper and tapered force feed chamber, as well as coupling rod with patented, positioned feeding screw for optimal transfer of the medium to the rotor and stator. The ideally placed flushing stud at the hopper housing sees to the best (possible) blending of the substrates.

### Further information

NEMO® B.Max®  
Brochure NMP · 060

# NEMO® Progressing Cavity Pumps

## Applications, Performance and Product Range

The pumps are designed and manufactured according to EHEDG and QHD-standards; they are suitable for CIP and SIP and are constructed in accordance with the US 3-A Sanitary Standards. Three rotor/stator geometries are available for optimal performance\*.

### Range of Applications

For hygienic applications and optimal cleaning in food, pharmaceutical, cosmetics and chemical/biochemical industries for non-viscous up to highly viscous fluids with or without solids.

### Further information

Business Field Food & Pharmaceutical  
Brochure NMP · 308

### NEMO® BH

Hygienic pump

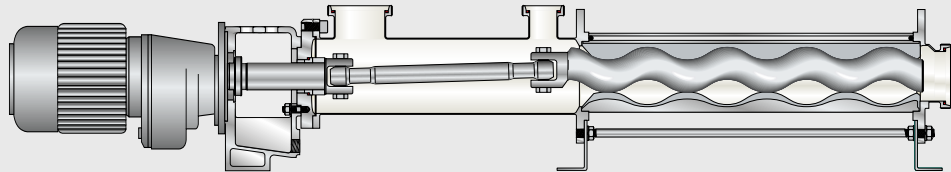

### Performance

Capacities up to 200 m<sup>3</sup>/h (880 gpm). Pressures up to 24 bar (340 psi).

### Description

Compact design with directly flanged drive resulting in low initial investment and economical operation and maintenance.

### NEMO® SH

Hygienic Plus pump

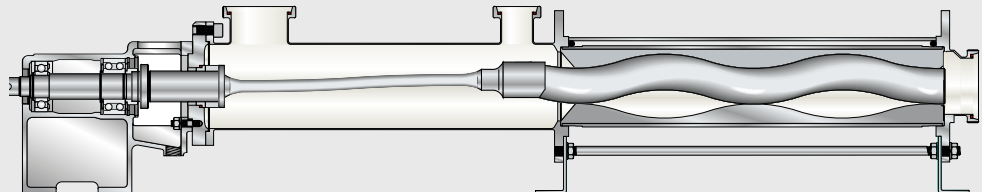

### Performance

Capacities up to 140 m<sup>3</sup>/h (620 gpm). Pressures up to 24 bar (340 psi).

### Description

The crevice, wear and maintenance-free flexible rod allows the conveyance of highly sensitive and abrasive products. Design with bearing housing and drive shaft allows for the use of all types of drives.

## NEMO® MINI BH

Mini Hygienic Plus pump

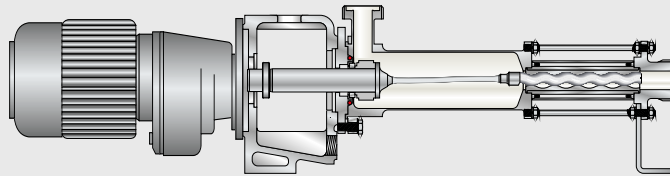

### Performance

Capacities of 0.1 up to 500 l/h (0.025 up to 130 gph). Pressures up to 36 bar (510 psi).

### Description

The smooth crevice-free flexible rod requires no maintenance and is not subject to wear, thus enabling the conveyance of highly sensitive and abrasive products. Compact design with directly flanged drive resulting in low initial investment and economical operation and maintenance. High dosing accuracy (deviation < 1 %).

## NEMO® SA

Aseptic pump

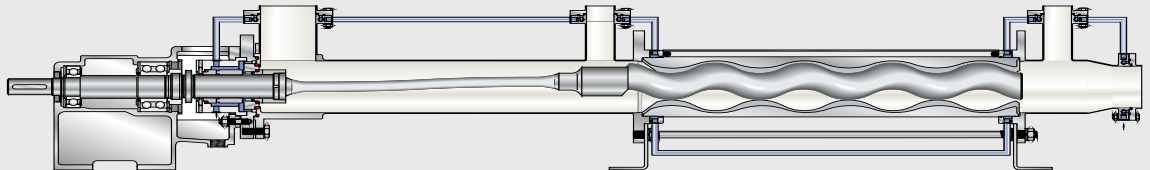

### Performance

Capacities up to 140 m<sup>3</sup>/h (620 gpm). Pressures up to 24 bar (340 psi).

### Description

The smooth crevice-free flexible rod requires no maintenance and is not subject to wear, thus enabling the conveyance of highly sensitive and abrasive products. The pump housing has a reduced diameter as well as a product entry moved towards the shaft seal (discharge in vertical position). This creates an absolutely crevice-free pump body generating an optimised flow of the product through the pump. For complete self-emptying, flushing ports are arranged tangentially and pressure ports are arranged eccentrically. To avoid contamination from the atmosphere, all seals are equipped with connections for flushing with sterile fluids, vapour or condensate and fitted with optional tubing. For changing product temperatures a standard stator with reduced wall thickness and a stator protector for dry running and overheating protection is available. Design with bearing housing and drive shaft allows for the use of all types of drives.

# NEMO® Immersible Pumps

## Applications, Performance and Product Range

**NEMO® semi-submersible pumps are used for emptying barrels, containers, tanks, clarifiers, pits, etc. They are also used where space is limited and when cavitation may be a danger or where low NPSH is available.**

**Furthermore the pumps are suitable for emptying barrels containing materials harmful to water and the environment where emptying through a connection at the bottom of the barrel is not permitted.**

### Performance

Capacities up to 140 m<sup>3</sup>/h (620 gpm).  
Pressures up to 24 bar (340 psi).

Depending on the application a number of designs/immersion variations are available. The immersion depth is adjusted as required by the application.

### Description

Compact design with directly flanged drive. Four rotor/stator geometries for optimal performance. Immersion depth up to 10 m. The length of the immersed tube can be modified by using an extended pump housing or an additional suction pipe or a combination of both.

### NEMO® Immersible Pump BT with Suspension Bracket

This pump is used for emptying open barrels and containers. It is equipped with a suspension bow for crane suspension. Immersion depth up to 3 m.

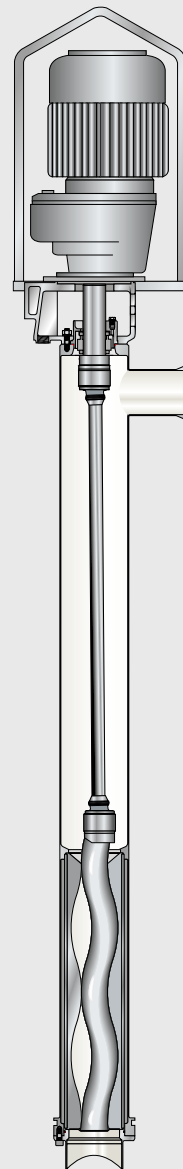

NEMO® Immersible Pump BT with suspension bracket

## NEMO® Immersible Pump BT with integral Mounting Plate

This pump is used in closed pits, tanks and containers where there is the possibility to vertically flange mount the pump to the tank lid. Depending on pump size, speed and immersion depth up to 10 m, an additional support guide is available to secure the pump to the bottom or to the wall near the bottom. Removal of the pump from a full tank is possible because the guide units are self-centering and secure the pump suction without fixings.

The pump with discharge connection below the mounting position the discharge connection of the pump is below the tank lid. The product is either piped to the outside vertically through the lid via a 90 ° elbow or horizontally through the tank wall. This minimises the dead space in the pump housing thus reducing the overall height of the pump above the tank lid. This version is normally used where there is only limited space available.

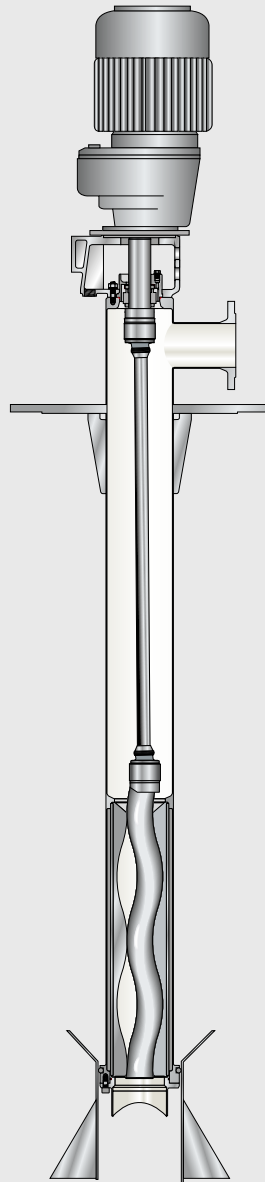

NEMO® Immersible Pump BT with integral mounting plate and horizontal discharge connection

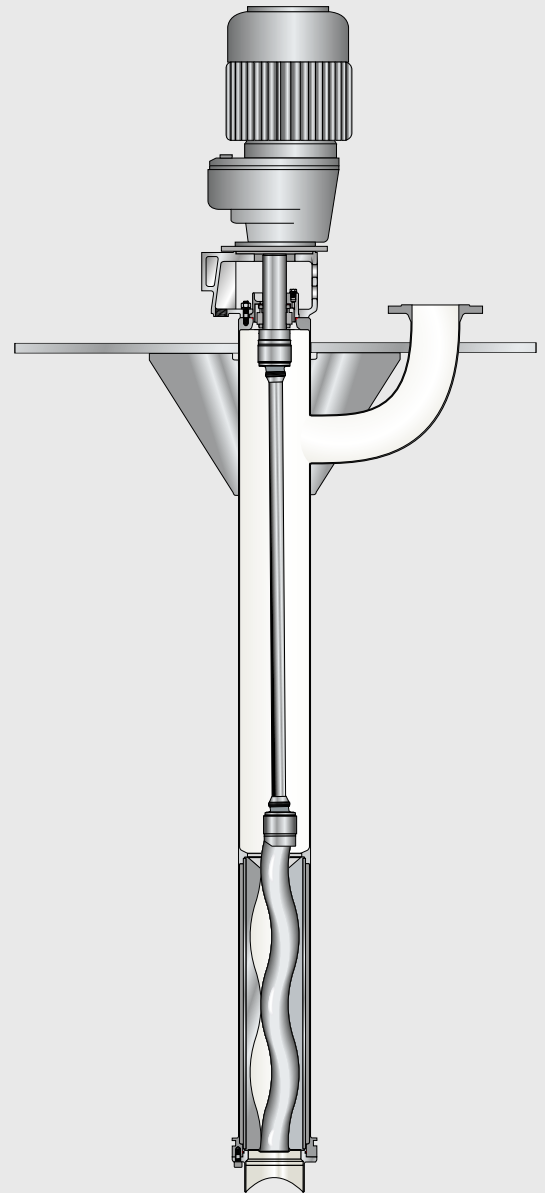

NEMO® Immersible Pump BT with integral mounting plate and vertical discharge connection

# Operational Characteristics and Conveying Principle of NEMO® Pumps in Different Geometries

## Modular Design

**NEMO® Pumps belong to the group of rotary positive displacement pumps. The conveying elements consist of the rotor which rotates within the fixed stator.**

As all four pump geometries have the same outer dimensions, we have a modular design where - apart from rotor and stator - all other components are identical. When a change in flow rate or pressure is required, installed NEMO® Pumps can be adapted to the new operating conditions by simply changing rotor and stator.

## S/L Geometry

The single helical screw/rotor has a circular cross section, an extremely long pitch and large thread depth which oscillates when the rotor is turned within the fixed stator. The cross section of the stator is the same profile as that of the rotor, however, the stator is a 180° internal twin start thread. As a result of the 1/2 ratio lobe geometry cavities are formed between the rotor and stator when the two are put together. By the turning movement of the rotor the progressing cavities between rotor and stator transport the fluid in a smooth and continuous manner from the suction to the discharge side of the stator. The flow rate is determined by the pitch of the

rotor/stator, diameter and eccentricity as well as the speed of the pump. The pressure capability depends on the number of stages and the differential pressure per stage up to 6 bar (85 psi). The 2-stage NEMO® Pump in S geometry can reach a differential pressure up to 12 bar (170 psi) with a flow rate of 100%. A single-stage NEMO® Pump in L geometry, has the same outer dimensions as the 2-stage pump in S geometry, the same diameter and eccentricity but a pitch double that of the S geometry rotor/stator. Therefore, the pump produces a flow rate of 200% when compared to the S geometry at a differential pressure of up to 6 bar (85 psi).

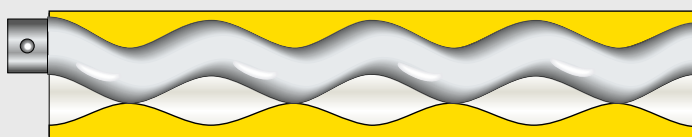

- 1/2 lobe
- Double stage
- Flow rate: 100%
- Differential pressure: 12 bar (170 psi)

### S Geometry

- Very smooth conveyance
- Compact dimensions despite high number of stages
- Large cross sections of rotor inlet
- Low flow velocity
- Conveyance of compacted products possible
- Conveyance of large solid particles



- 1/2 lobe
- Single stage
- Flow rate: 200%
- Differential pressure: 6 bar (85 psi)

### L Geometry

- Greater volumetric efficiency/long service life due to long seal lines between rotor and stator
- Compact dimensions together with high flow rates

## D/P Geometry

The twin start helical rotor has an elliptical cross section, a long pitch and large thread depth. It rotates within a circular eccentric motion within the fixed stator, the form of which is the same geometry as the rotor, however, the stator is a triple start internal thread with 120 ° interval starts. As a result of the 2/3 ratio lobe geometry cavities are formed between the rotor and stator when the two are put together. By the turning movement of the rotor, the progressing cavities between rotor and stator transport the fluid in a smooth

and continuous manner from the suction to the discharge side of the stator. The flow rate is determined by the pitch of rotor/stator, elliptic diameter and eccentricity as well as the speed of the pump. The pressure capability depends on the number of stages with the differential pressure being up to 6 bar (85 psi) per stage. In D/P geometry the cavities are approximately 75% of the size of the S/L geometry however they open twice per revolution compared to once per revolution in 1/2 stage geometries. Therefore D/P geometry rotors/stators

have a 50% increase in the flow per revolution compared to S/L geometry. The 2-stage NEMO® Pump in D geometry can reach differential pressures of up to 12 bar (170 psi) at a flow rate of 150% over that of the S geometry. A single-stage NEMO® Pump in P geometry, has the same outer dimensions as the 2-stage pump in D geometry, the same ellipse and eccentricity but a pitch double that of the D geometry rotor/stator. Therefore the pump produces a flow rate of 300% over that of the S geometry at a differential pressure of up to 6 bar (85 psi).

### D Geometry

- Extremely compact dimensions despite high pressures and flow rates capabilities
- Almost pulsation free conveyance
- High dosing accuracy



- 2/3 lobe
- Double stage
- Flow rate: 150%
- Differential pressure: 12 bar (170 psi)

### P Geometry

- Compact dimensions in conjunction with very high flow rates
- Almost pulsation free conveyance
- High dosing accuracy
- Good volumetric efficiency/long service life due to long seal line between rotor and stator



- 2/3 lobe
- Single stage
- Flow rate: 300%
- Differential pressure: 6 bar (85 psi)

## Type of Joints

# The Proper NEMO® Joint for Every Application

The correct joint design in a NEMO® Pump has a decisive influence on the operational reliability and life cycle cost. The optimal joint for the respective pump series is selected

depending upon application, operational conditions as pump series is selected depending upon application, operational conditions as well as the flow rates.

### B Universal Pin Joint

The NEMO® universal pin joint is the standard joint for NEMO® industrial pumps because of its simple design and outstanding reliability. To achieve a long service life, the joint is oil filled and sealed by the NEMO® SM® seal. The joint can also be used without seal in case of extremely high temperatures and products where elastomers are not suitable. The joint consists of a minimum number of parts that enables simple dismantling for maintenance.

### V Pin Joint

The operational characteristics of the NEMO® V pin joint are similar to those of the B pin joint. For longer service life in difficult applications they are strengthened by hardened bushings fitted into boreholes in the coupling rod and the rotor/drive shaft head. The V pin joints with hardened bushes are easy to remove for maintenance purposes. Standard on the 125 pump size.

### H Hygienic Pin Joint

The open, patented pin joint was designed specifically for use in hygienic pumps. It is crevice and dead space free, polished and, therefore, easy to clean. The joint is made in accordance with US 3-A Sanitary Standards.

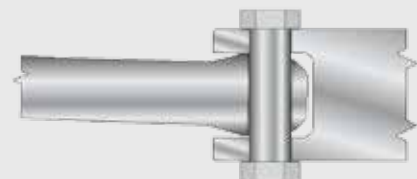
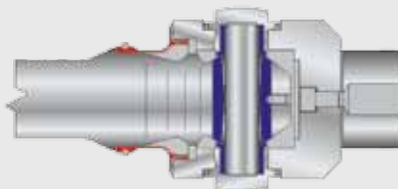
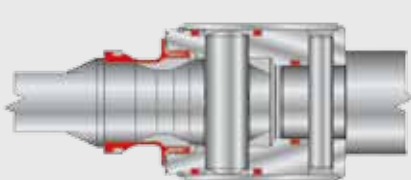



## F NEMO® Flextec Flexible Rod

The flexible rod is wear- and maintenancefree because there are no components moving against each other as in other joint types. Neither lubrication nor seals are required. Therefore, the flexible rod is suitable for high pressures and temperatures. The flexible rod is also free from crevices and dead spaces which allows it to be used for pumping highly sensitive products in aseptic conditions. It is designed in accordance with the US 3-A Sanitary Standards.



## K Joint

The patented K joint was designed for extremely arduous industrial applications involving constant pump running, frequent stop/starts or shock loads. It is kinematically designed so that the torque and axial loads are borne by separate elements within the joint. The joint is oil filled and hermetically sealed by two seals which are resistant (compatible) against the lubricant and the pumped product. Filling the space between the two seals with oil allows the use of the joints at pressures up to 12 bar (170 psi).

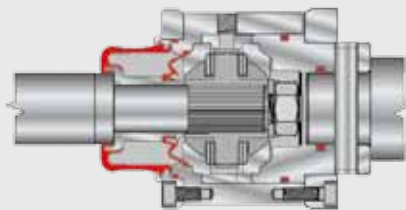

## Z Double Seal Pivot Joint

For the largest flows and pressures possible with NEMO® pumps where the torques and axial loads are at their highest (in bearing housing size NM 125SY and above) the pumps are fitted as standard with a cartridge type precision pivot joint. The joint is oil filled, hermetically sealed by two seals which are resistant (compatible) against the lubricant and the pumped product. It is suitable for continuous operation.

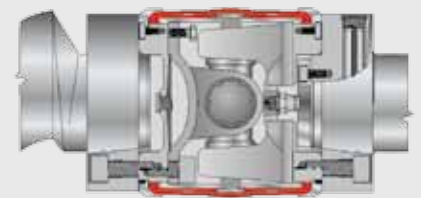

## Accessories to increase the operational safety of both pump and plant and to prevent downtimes

### Process monitoring

Dry running protection devices avoid thermal destruction of elastomere parts and protect the pump and accessory equipment.

- Dry running protection (STPA2A, STP2D)
- Flow sensing units for solid stators
- Speed monitoring device

Over-/underpressure protection devices protect the pump and accessory equipment from unsuitable pressures, therefore increasing the operating reliability of the pump and minimising downtime.

- Diaphragm Pressure Gauge
- Pressure control device DTSL 3
- Multi-function pressure instrument
- By-pass line

### Seal Support Systems

To ensure the problem free operation of a shaft seal system it is often necessary to install a quench, flushing or pressurised barrier system so that the seal operates in ideal conditions.

- Quench pot
- Permanent lubricator
- Pressurised flush for double mechanical seals

### Tools and optional extras

For simple maintenance and problem free operation many helpful tools and accessories are available.

- Gear joint filling unit
- Ring dosing nozzle
- Chemical anchor
- Stator removal tool

### Protection Units and Trolleys

In all production areas within the food, pharmaceutical and cosmetic industries a range of mobile and fixed mounting optionals are available to ensure hygiene of the highest standard.

- Covers for drive motors
- Trolley assemblies
- Machine feet

### Further information

NETZSCH Original-Accessories  
Brochure NMP · 343

## NETZSCH Service

### Your Benefit

Consulting, service and quality are our strengths. When buying the pump you have decided on a quality product by NETZSCH with good reason. Strict quality standards, tests and the certification according to DIN EN ISO 9001 guarantee all parts are of a consistent quality to the highest degree. In order to maintain the capacity and quality of your pump, we will support you in all matters, also after the delivery of the pump. The experience from more than 500,000 pumps installed is the basis for this.

### Spare Parts and Service

In your area well-trained service partners are available for quick and economic service of the pumps at your premises. You will find your personal service partner in our homepage at [www.netzsch.com](http://www.netzsch.com) | Pumps & Systems | Consultation/Service.



The NETZSCH Group is an owner-managed, internationally operating technology company headquartered in Germany.

The three Business Units – Analyzing & Testing, Grinding & Dispersing and Pumps & Systems – provide tailored solutions for highest-level needs. Over 2,500 employees at 130 sales and production centers in 23 countries across the globe guarantee that expert service is never far from our customers.

The NETZSCH Business Unit Pumps & Systems offers with NEMO® progressing cavity pumps, TORNADO® rotary lobe pumps, screw pumps, macerators/grinders, dosing systems and equipment custom built and challenging solutions for different applications on a global base.

NETZSCH Pumpen & Systeme GmbH  
Geretsrieder Straße 1  
84478 Waldkraiburg  
Germany  
Tel.: +49 8638 63-0  
Fax: +49 8638 67 981  
info.nps@netzsch.com  
www.netzsch.com

